



## Level Meter Based on Displacer Principle for liquids



measuring  
•  
monitoring  
•  
analysing



- Level metering and monitoring of liquids
- Robust design
- Clear 90°-scale
- Transmitter with HART® or PROFIBUS-PA as option

BA



N2

KOBOLD companies worldwide:

ARGENTINA, AUSTRALIA, AUSTRIA, BELGIUM, BULGARIA, CANADA, CHILE, CHINA, COLOMBIA, CZECHIA, EGYPT, FRANCE, GERMANY, GREAT BRITAIN, HUNGARY, INDIA, INDONESIA, ITALY, MALAYSIA, MEXICO, NETHERLANDS, PERU, POLAND, REPUBLIC OF KOREA, ROMANIA, SINGAPORE, SPAIN, SWITZERLAND, TAIWAN, THAILAND, TUNISIA, TURKEY, USA, VIETNAM

KOBOLD Messring GmbH  
Nordring 22-24  
D-65719 Hofheim/Ts.  
Head Office:  
+49(0)6192 299-0  
+49(0)6192 23398  
info.de@kobold.com  
www.kobold.com



## Description

The KOBOLD level indicator model BA is suitable for level measurement of liquid products in open containers and inside containers under pressure. The device is based on Archimedes principle. The displacer rod, which is attached to a measuring spring using a chain, immerses into the liquid and is subject to a buoyant force proportional to the mass of the displaced liquid.

Every change in the weight of the rod corresponds to a change in the length of the spring and is therefore a measure of the liquid level. The longitudinal expansion of the spring, i.e. the travel of the rod, will be transmitted from the measuring space to the indicator unit by means of a magnetic coupling.

The basic version of the indicator unit consists of a scale with a pointer for displaying the liquid level. As an option, the indicator unit may be equipped with electrical transmitters for remote display or with limit switches.

If the device cannot be installed from above, because, for example, a stirrer is mounted in the container, a special displacement vessel is available for lateral installation. Since the buoyancy of the displacer rod depends on the density of the measured medium, it must have been designed for the specific liquid to be measured.

The meter's design makes it ideal for processes under difficult and rough operating conditions. The devices are available with additional electrical equipment for process monitoring and control.

## Additional Advantages:

- A large spectrum of wetted materials
- Magneto-resistive signal transmission
- Swilling well for rough conditions (optional)
- High-temperature application (option)
- High-pressure application (option)
- Excellent heat tracing technology (option)

## Applications

- Storage tanks
- Stirring tank
- Water tanks
- Tanks with aggressive media

## Technical Details

Measuring principle:	displacer principle
Accuracy:	±5 mm of measured value ±0,2% with transmitter ES
Density range:	400...2 000 g/L
Process temperature:	-40 °C ... +250 °C
Ambient temperature:	-40 °C ... +80 °C (mounting part) -40 °C ... +80 °C (display without contact) -40 °C ... +65 °C (display with contact) -40 °C ... +70 °C (transmitter)
Nominal pressure:	PN 40, ASME CI 150 / 300 (standard) higher pressure up to PN 400 on request
Materials:	Sensor: stainless steel, other materials on request Display: aluminium (stove enamelled), stainless steel (optional)
Process Connection:	DN 50 flange acc. EN 1092, 2" flange acc. ASME B16.5 other connection sizes on request
Electrical output:	inductive limit switch, microswitch, others on request
Transmitter:	ES with HART®-Protocol, 4-20mA ES with HART®-Protocol, 4-20mA and 2 NAMUR-switches ES with Profibus PA others on request
Output:	passive, galvanically isolated
Analogue:	4-20 mA
Binary 1 and 2:	$U_i = 30 \text{ V}$ , $I_i = 20 \text{ mA}$ , $P_i = 100 \text{ mW}$
Power supply:	14-30 V <sub>DC</sub>
Protection:	IP 65 (EN60529) mounting part IP 65 (EN60529) display aluminium IP 67 (EN60529) display stainless steel IP 20 (EN60529) transmitter

## Certificates and approvals

Explosion-protection:	TÜV 02 ATEX 1926 X
Explosion-protection:	DMT 00 ATEX E 075
Ignition protection type:	Ⓔ II 2G EEx ia IIC T6
CE-marking:	Ex-directive 94/9/EG



**Order details** (Example: BA-S0 XXXX 0 321B 0 S 0 1 1 0)

Model	Displacer rod length* (= measuring length) in mm	Displacer rod for separation-layer measurement	Process connection**	Air vent plug
<b>BA-S0</b> = stainless steel, Cat. 2 <b>BA-S1</b> = stainless steel, Cat. 1, 2 (II 1/2G EEx ia IIC T6..T1) <b>BA-XX</b> = Special material	<b>XXXX</b> = type 1 or type 2 (depending on calculation of dimensioning software)	<b>0</b> = without <b>1</b> = with (minimum density difference 150 g/L) <b>X</b> = special version	<b>321B</b> = DN50, PN40, form B1 acc. DIN EN 1092-1 <b>331B</b> = DN80, PN40, form B1 acc. DIN EN 1092-1 <b>335B</b> = DN100, PN16, form B1 acc. DIN EN 1092-1 <b>206R</b> = 2" Class 150 RF, ASME B16.5-2003 <b>208R</b> = 3" Class 150 RF, ASME B16.5-2003 <b>210R</b> = 4" Class 150 RF, ASME B16.5-2003 <b>226R</b> = 2" Class 300 RF, ASME B16.5-2003 <b>228R</b> = 3" Class 300 RF, ASME B16.5-2003 <b>230R</b> = 4" Class 300 RF, ASME B16.5-2003	<b>0</b> = without

Display	Display version	Scale	Electrical output***	Accessories
<b>S</b> = standard <b>E</b> = stainless steel display	<b>0</b> = standard <b>H</b> = assembled at distance of 100 mm upwards, with cooling section, for vessel mounting max. 150 °C <b>K</b> = assembled at distance of 100 mm upwards and forward, with cooling section, for vessel mounting max. 250 °C <b>V</b> = assembled at distance of 100 mm forward, with cooling section, for bypass- mounting, max. 250 °C <b>X</b> = special version	<b>1</b> = %-scale (water) <b>2</b> = MB-scale (water) <b>4</b> = %-scale (measured media) <b>5</b> = MB-scale (measured media) <b>X</b> = special version	<b>0</b> = without <b>1</b> = 1x inductive limit switch <b>2</b> = 2x inductive limit switches <b>6</b> = electronic transmitter ES, HART® protocol, 4-20 mA, EEx ia <b>7</b> = electronic transmitter ES, HART® protocol, 4-20 mA, EEx ia, 2x Namur contacts <b>9</b> = electronic transmitter ES, Profibus-PA®, EEx ia <b>D</b> = 2 x micro switches <b>K</b> = electronic transmitter ES, Fieldbus® Foundation	<b>0</b> = without <b>X</b> = with (see separate specification)

\* When specifying the displacer rod length respectively the measuring length (distance A), please use 4 digits. Fill up unused digits with zero

\*\* Process connection in DN80, DN100, 3" and 4" on request

\*\*\* Other electrical outputs on request. Except for the micro level switches, all other switching points must be defined when ordering and will be factory set.

**For dimensioning of the level meter model BA the following data is mandatory beside the specification given in the order details:**

- Distance from the media surface at its maximum up to the sealing surface of the mounting flange (distance B)
- Density of the medium at operating conditions
- Minimum and maximum operating temperature
- Operating pressure

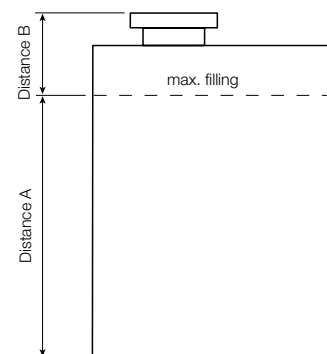

**Dimensions**

**Display aluminium**

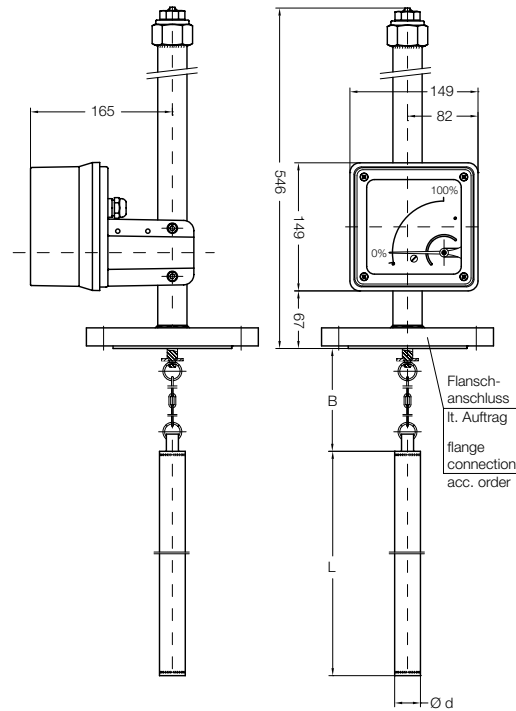

**Display stainless steel**

