



## Conductive Level Switch



measuring  
•  
monitoring  
•  
analysing

LNK



- $p_{\max}$ : 10 bar;  $t_{\max}$ : 100 °C  
150 °C for CIP process
- 1 to 4 electrode stems,  
any lengths up to 1500 mm
- Process connections:  
G 1/2, G 1  
installation meets hygiene  
standards through installation  
system LZE
- Materials approved for  
handling of foodstuffs
- Optional head mounted  
transmitter
- Optional: E-CTFE coating



Weld-in sleeve LZE



KOBOLD companies worldwide:

ARGENTINA, AUSTRALIA, AUSTRIA, BELGIUM, BULGARIA, CANADA, CHILE, CHINA, COLOMBIA, CZECHIA, EGYPT, FRANCE, GERMANY, GREAT BRITAIN, HUNGARY, INDIA, INDONESIA, ITALY, MALAYSIA, MEXICO, NETHERLANDS, PERU, POLAND, REPUBLIC OF KOREA, ROMANIA, SINGAPORE, SPAIN, SWITZERLAND, TAIWAN, THAILAND, TUNISIA, TURKEY, USA, VIETNAM

KOBOLD Messring GmbH  
Nordring 22-24  
D-65719 Hofheim/Ts.  
Head Office:  
+49(0)6192 299-0  
+49(0)6192 23398  
info.de@kobold.com  
www.kobold.com

**Description**

The conductive KOBOLD level probes LNK together with the transducer for head mounting or the external evaluating electronic are used for level monitoring. This method is based on the evaluation of the electrical conductivity of the medium. In combination with the KOBOLD LZE or LZE-R weldin sleeves, the probe provides a measuring point that has no dead space and meets hygiene standards. This level switch is therefore ideally suited for CIP/SIP cleaning.

The level switch is available with 1 or 2-4 electrodes, also available with E-CTFE coating. This allows foaming media to be detected reliably.

The output signal from the probes with head mounted transmitter can be connected directly to a PLC for evaluation. This means lower installation costs, minimum wiring requirements and a high degree of noise immunity.

The device is available with an optional M12x1 plug connector.

**Applications**

- Level monitoring in all conductive media

**Technical Details**

Measuring principle: conductive  
 Process temperature: 0... 100 °C, 150 °C for CIP process  
 Ambient temperature: 0... 70 °C  
 Operating pressure: max. 10 bar

**Material**

- Head, thread supports: stainless steel 1.4404
- Insulating section: PEEK
- Electrode stem: stainless steel 1.4404
- Stem coating: E-CTFE, coating 0.3 mm
- Electrode length: 4 - 1500 mm
- Process connection: G 1/2 with 1 electrode stem  
G 1 bei 2-4 electrode stems
- Connection: cable gland connection M16x1.5  
optional M12x1 plug
- Protection: IP 67
- Min. conductivity: 10 µS/cm
- Weight: approx. 0.6 kg

**Switch electronics**

**For 1- or 2-stem probe: internal level module for one switch point, option NPK/NPS (see LNR)**

Power supply: 15... 36 V<sub>DC</sub>, 15 mA  
 Electrode voltage: approx. 2 V<sub>AC</sub> / 600 Hz  
 Sensitivity (adjustable): 4 steps 0, 1/1/10/100 kΩ  
 Function: full /empty report (determined via the polarity of the supply voltage)  
 Output: PNP transistor output (open collector),  
 U<sub>off</sub> = +Vs - 1 V  
 max. 50 mA, short-circuit-proof  
 Switch delay (fixed): 1 s  
 Weight: approx. 40 g

**For 1- up to 4-stem probe: external electrode relay NE-104 and NE-304 (see data sheet N1-NE)**

**Dimensions [mm]**

**1-stem probe**

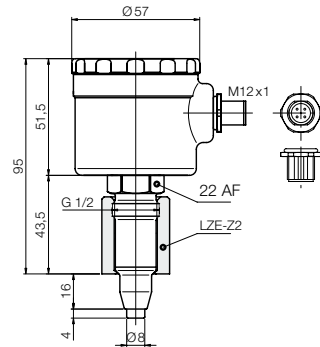

**Multi stem probe**

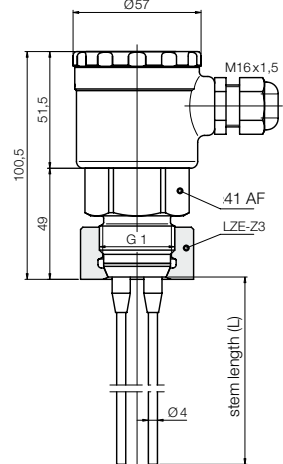

**Order Details (Example: LNK-1 2 0 A A A A 00K)**

Model	Design (Process connection)	Electrode material	Electrode coating	Length 1. stem	Length 2. stem	Length 3. stem	Length 4. stem	Evaluation/ electronic connection
LNK-	1 = 1 electrode (G 1/2)	2 = stainless steel	0 = without coating E = E-CTFE coating	A = 4 mm stump	A = 4 mm stump	A = 4 mm stump	A = 4 mm stump	<b>00K</b> = without electronics, cable connection M16x1,5 <b>00S</b> = without electronics, M12x1 plug <b>only for 1- or 2-stem probe:</b> <b>NPK</b> = switching electronics; PNP switch output; thread. cable connection <b>NPS</b> = switching electronics; PNP switch output, M12x1 plug
	2 = 2 electrodes (G 1)			B = 100 mm	B = 100 mm	B = 100 mm	B = 100 mm	
	3 = 3 electrodes (G 1)			C = 250 mm	C = 250 mm	C = 250 mm	C = 250 mm	
	4 = 4 electrodes (G 1)			D = 500 mm	D = 500 mm	D = 500 mm	D = 500 mm	
				E = 750 mm	E = 750 mm	E = 750 mm	E = 750 mm	
				F = 1000 mm	F = 1000 mm	F = 1000 mm	F = 1000 mm	
				G = 1500 mm	G = 1500 mm	G = 1500 mm	G = 1500 mm	
				0 = no other stem	0 = no other stem	0 = no other stem	0 = no other stem	

External switch electronic: Electrode relay NE-104 and NE-304.