



Guided Wave Radar Level Transmitter (TDR)



measuring
•
monitoring
•
analysing

NGR



- For liquids
- Independent of density, temperature, pressure, humidity and conductivity
- Probe length: max. 2000 mm
- Temperature range: -20 ... +100 °C
- Pressure range: -1 ... +10 bar
- Output: 4 - 20 mA / 0 - 10 V switching output PNP or NPN

N2



KOBOLD companies worldwide:

ARGENTINA, AUSTRALIA, AUSTRIA, BELGIUM, BULGARIA, CANADA, CHILE, CHINA, COLOMBIA, CZECHIA, EGYPT, FRANCE, GERMANY, GREAT BRITAIN, HUNGARY, INDIA, INDONESIA, ITALY, MALAYSIA, MEXICO, NETHERLANDS, PERU, POLAND, REPUBLIC OF KOREA, ROMANIA, SINGAPORE, SPAIN, SWITZERLAND, TAIWAN, THAILAND, TUNISIA, TURKEY, USA, VIETNAM

KOBOLD Messring GmbH
Nordring 22-24
D-65719 Hofheim/Ts.
Head Office:
+49(0)6192 299-0
+49(0)6192 23398
info.de@kobold.com
www.kobold.com



Description

The NGR is a level sensor that uses TDR technology (time domain reflectometry) and thus can be used in oil- and water-based liquids without calibration. The NGR's guided radar uses time-of-flight technology to measure electromagnetic pulses. The time difference between the sent pulse and the reflected pulse is used to calculate the level, both as a continuous value (analogue output) and a freely positionable switching point (switching output).

Due to its flexible probe that can be changed or cut, it is possible to integrate the sensor quickly into any application. The NGR can work in deposit-forming and foaming liquids. The sensor's intuitive setup uses four buttons and a display to ensure quick and easy adaptation to the application.

Your Benefits

- No mechanical moving parts
- Manually cuttable and exchangeable monoprobe with lengths from 200 mm up to 2 000 mm
- Immune to deposit formation
- Process temperature up to 100 °C; process pressure up to 10 bar
- Small inactive areas, ideal for small containers
- Accurate measurement, even when liquid type changes
- 3-in-1: combined display, analogue output (acc. NAMUR NE 43) and binary output
- High enclosure rating of IP67, rotatable housing
- Rugged design increases service life
- High flexibility due to cuttable and exchangeable monoprobe
- Cost savings due to multiple output signals: one system for both level detection and continuous level monitoring
- Time and cost savings due to low maintenance and quick commissioning
- No calibration or recalibration required for commissioning, thus saving time and costs
- Compact and rotatable housing ensures flexible installation
- No crosstalk when several sensors are mounted next to each other
- Advanced technology enables adjustment-free measurement of oil and water-based liquids
- Coaxial version for plastic tanks or $DK \geq 1.8$

Technical Details

Medium:	fluids
Measurement:	switch, continuous
Probe length:	200 mm ... 2 000 mm (Standard = 2000 mm, shortening possible by customer)
Process pressure:	-1 bar ... 10 bar
Process temperature:	-20 °C ... +100 °C
RoHS certificate:	yes
Accuracy of sensor element ¹⁾ :	±5 mm
Repeatability:	≤2 mm
Resolution:	<2 mm
Response time:	<400 ms
Dielectric constant:	≥5 for mono probe ≥1.8 with coaxial tube
Conductivity:	no limitation
Max. level change:	≤500 mm/s
Inactive area at probe end ¹⁾ :	10 mm
Inactive area at process connector ²⁾ :	25 mm
Wetted parts:	1.4404, PTFE
Process connection:	G 3/4" A, 3/4" NPT
Housing material:	plastic PBT
Max. probe load:	≤6 Nm
Supply voltage ³⁾ :	12 V _{DC} ... 30 V _{DC}
Power consumption:	≤100 mA at 24 V _{DC} without output load
Initialization time:	≤2 s
Protection class:	III
Electrical connection:	M12x1, 5-pin M12x1, 8-pin

¹⁾ With water under reference conditions

²⁾ With parameterized tank with water under reference conditions, otherwise 40 mm.



Technical Details (continuation)

Output signal ³⁾ :	analogue output 4 mA ... 20 mA / 0 V ... 10 V automatic switching to a current or voltage output depending on the load. 1 PNP-transistor output and 1 PNP/NPN-transistor output switchable (Option 2) or 1 PNP-transistor output and 3 PNP/NPN-transistor output switchable (Option 4)	Inductive load:	< 1 H
Output load:	4 mA ... 20 mA < 500 Ω at U _v > 15 V, 4 mA ... 20 mA < 350 Ω at U _v > 12 V, 0 V ... 10 V > 750 Ω at U _v ≥ 14 V	Capacitive load:	100 nF
Hysteresis:	min. 2 mm, freely adjustable	Enclosure rating:	IP67: EN 60529
Signal voltage HIGH:	V _s - 2 V	Temperature drift:	< 0.1 mm/K
Signal voltage LOW:	≤ 2 V	Lower signal level:	3.8 mA ... 4 mA
Output current:	< 100 mA	Upper signal level:	20 mA ... 20.5 mA
		EMC:	EN 61326 -1:2006, 2004/108/EG
		Ambient operating temperature:	-20 °C ... +60 °C
		Ambient storage temperature:	-40 °C ... +80 °C

³⁾ All connections are polarity protected. All outputs are overload and short-circuit protected

Ordering Code Guided Wave Radar Level Transmitter Model NGR

Order Details (Example: **NGR-1 2 4 2 G5 B**)

Model	Version	Material	Signal Output	Contact	Connection	Probe length
NGR-	1 = single probe (metal tanks DK ≥ 5) 2 ²⁾ = coaxial (plastic tanks or metal tanks DK ≥ 1.8)	2 = stainless steel/ PTFE	4 = 4-20 mA/ 0-10 V switchable	2 = 1xPNP+1xPNP/NPN 4 = 1xPNP+3xPNP/NPN	G5 = G 3/4 male N5 = 3/4" NPT male	0 ¹⁾ = probe length 2000 mm (standard) L = Length 200 ... 2000 mm (specify in clear text) B ¹⁾ = mounted on bypass

¹⁾ Only possible with NGR-1. Bypass-specification, see NBK-M data sheet

²⁾ Using a coaxial tube improves signal detection, particularly in media with low DK values (e.g., oil)

Note: Standard probe length «L» = 2000 mm (NGR-1242G50 on stock). Probe length «L» available in steps of 10 mm. Example: 200, 210, 220, 230 ... 2000 mm. Please specify in clear text while ordering

Plug Connectors and Cables

Model	Brief description
ZUB-KAB-12K502	Cable, M12, 5-pin, straight connector female with molded cable, 2 m, PUR/PVC
ZUB-KAB-12K802	Cable, M12, 8-pin, straight connector female with molded cable, 2 m, PUR/PVC

Accuracy Diagrams [mm]

Accuracy diagram with parameterized tank

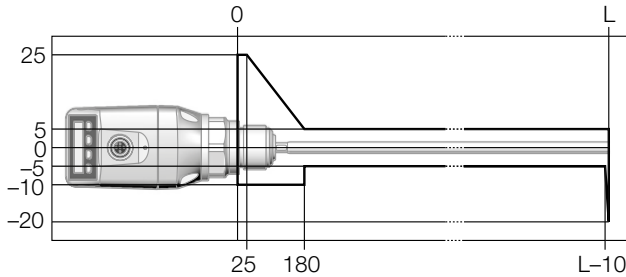

Accuracy diagram without parameterized tank

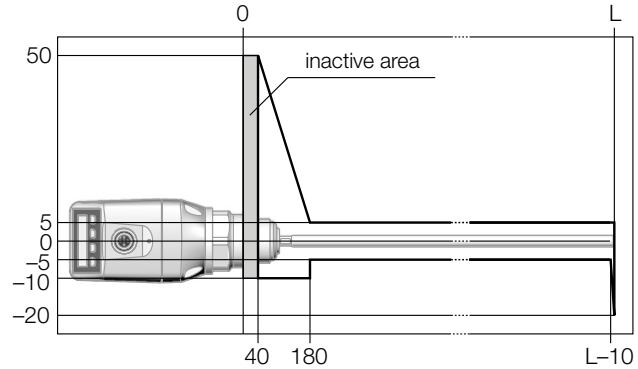

Reference conditions:

- Container with a diameter of 1 m
- Central installation of the sensor
- Minimum distance to built-in components >300 mm
- Distance from the end of probe to tank bottom > 15 mm
- Air humidity: 65% +/- 20%
- Temperature: +20 °C +/- 5 °C
- Pressure: 1013 mbar abs. +/- 20 mbar.
- Container parameterization undertaken
- Medium: water, DK = 80

Connection Type

5-pin

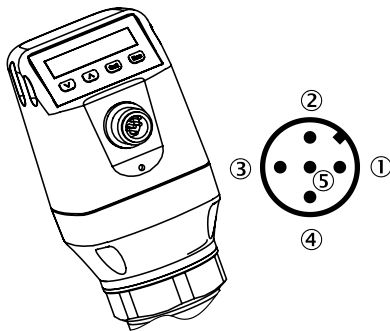

- 1 L⁺: supply voltage, brown
- 2 Q_A: analogue current-/voltage output, white
- 3 M: ground, reference ground for current-/voltage output, blue
- 4 Q₁: switching output 1, PNP, black
- 5 Q₂: switching output 2, PNP/NPN, grey

8-pin

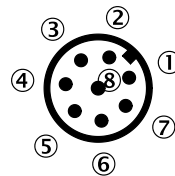

- 1 L⁺: supply voltage
- 2 Q₂: switching output 2, PNP/NPN
- 3 M: ground, reference ground for current-/voltage output
- 4 Q₁: switching output 1, PNP
- 5 Q₃: switching output 3, PNP/NPN
- 6 Q₄: switching output 4, PNP/NPN
- 7 Q_A: analogue current-/voltage output
- 8: no function

The wire colors in 8-pin cables are not standardized. Please note the wiring of the sensor.

Dimensions [mm]

Monoprobe

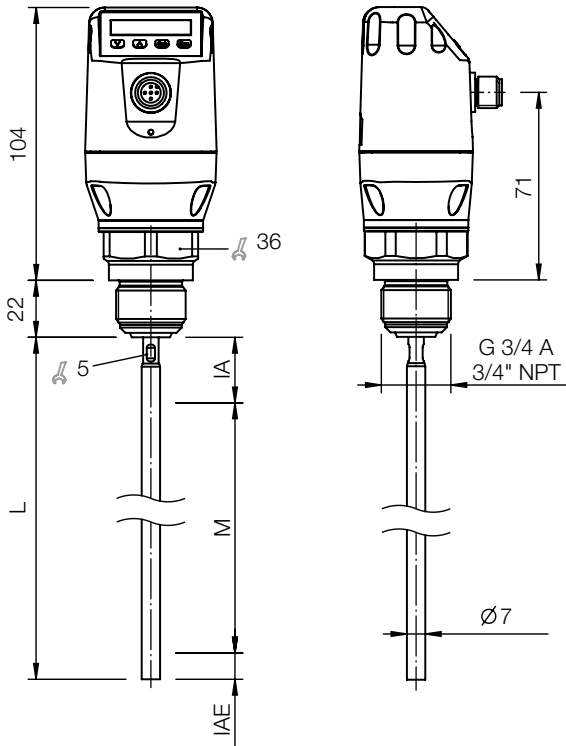

with coax tube

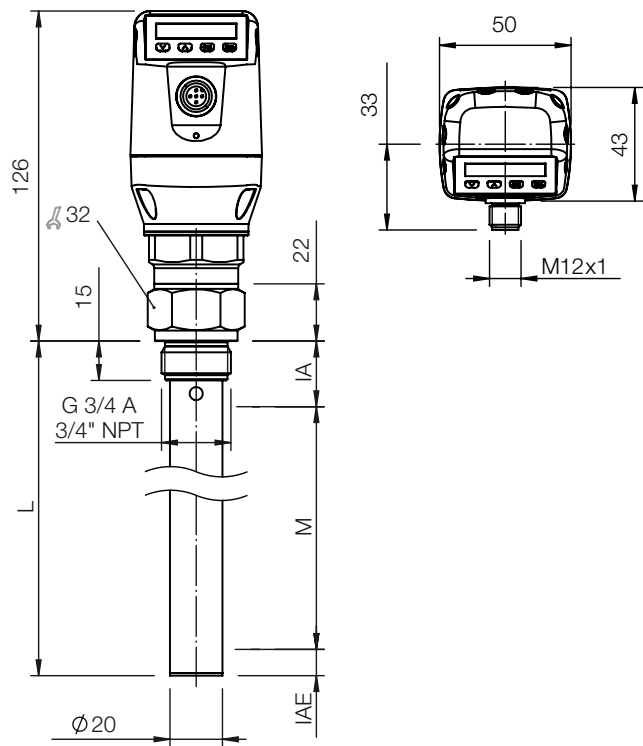

M: measuring range

L: probe length

IA: inactive area at process connection 25 mm

IAE: Inactive area at probe end 10 mm

Installation Instructions

Installation in a tank

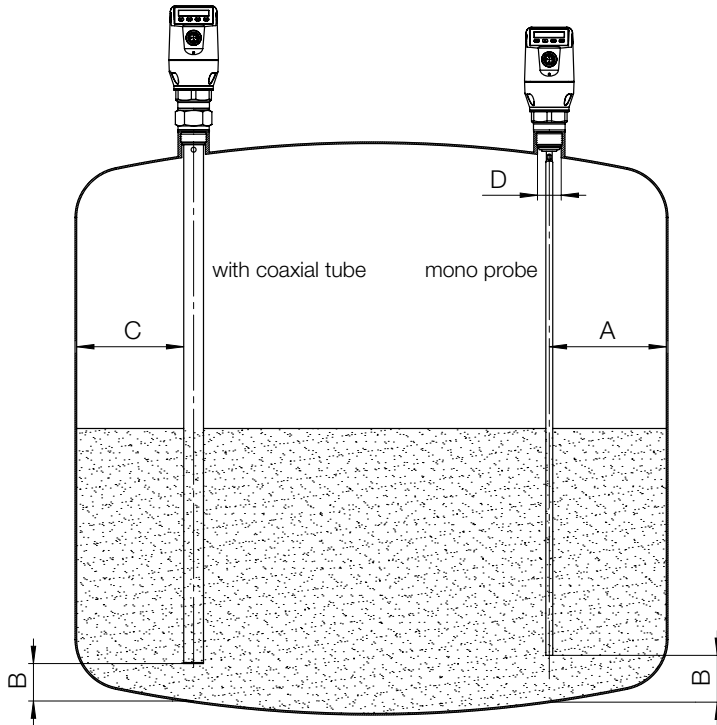

Unit with mono probe mounted in metal tank

Installation in nozzle:

$D \geq DN 25$

Distance tank wall/tank bottom:

$A \geq 50 \text{ mm}$

$B \geq 10 \text{ mm}$

Distance to other tank fittings:

$\geq 100 \text{ mm}$

Unit with coaxial tube for metal and non metal tank

C = with a coaxial tube there are no minimum distances to the tank wall or to other tank fittings required

Installation of a mono probe in a metal immersion tube or metal bypass

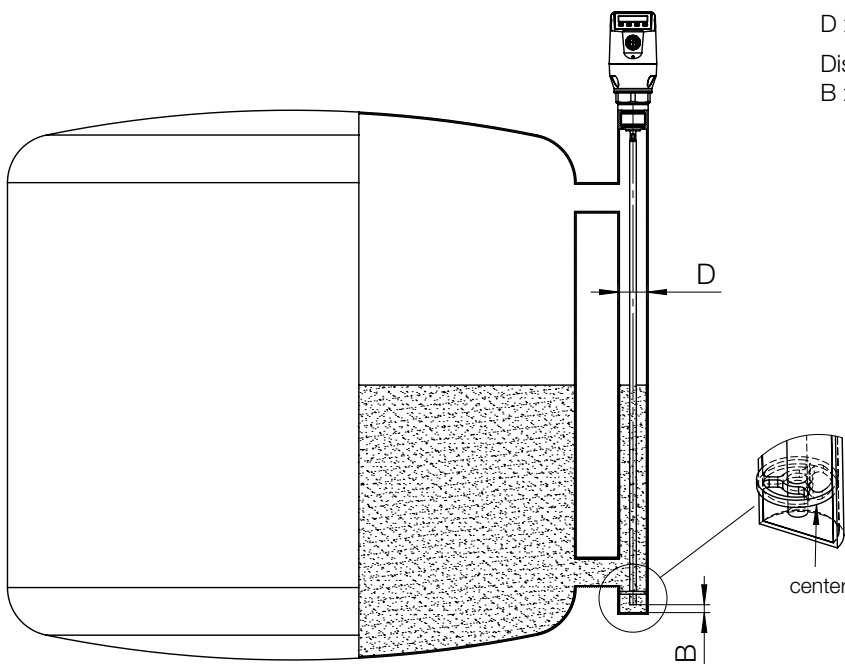

$D \geq DN 40$

Distance tank wall/tank bottom:

$B \geq 10 \text{ mm}$

Centering: To prevent contact between the probe and the bypass pipe during oscillations, the probe should be centered according to its length and depending on the diameter of the

bypass pipe. To do this, it is necessary to insert one or two centering pieces.